

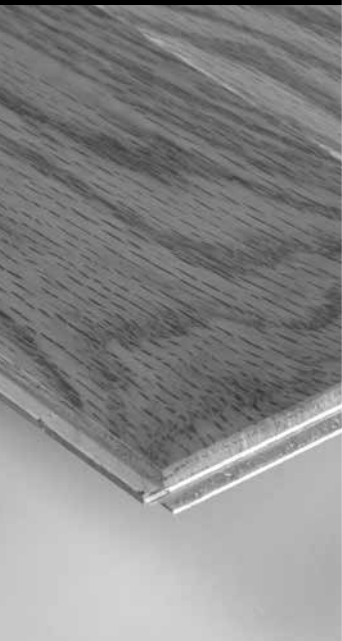

Installation Guide

Engineered Prefinished Hardwood Floors

VERSION FRANÇAISE AU VERSO



Please read all instructions carefully before installation. Improper installation may void the warranty.

PRODUCT USE

Mirage engineered products can be installed above, on or below grade. Most wood species, with the exception of Brazilian Cherry [Jatoba] and Hickory, can also be installed over subfloor equipped with radiant heat systems.

Mirage engineered products may either be glued down over plywood/OSB or concrete subfloor, or simply nailer/stapled down over plywood/OSB floor, using specially designed hardwood floor stapler or nailer.

INSTALLER AND OWNER RESPONSIBILITY

Prior to installation, the installer and owner must ensure that the work environment and subfloors meet or even exceed minimal specifications listed in this installation guide.

Standard trade practice allows for up to a 5% margin of error for natural imperfections and manufacturing defects. Prior to installation, the installer and owner should conduct a final inspection of grade, color, manufacturing and finish quality of boards to ensure that the floor conforms to purchased product.

Once installed, any board is considered as having been accepted by installer and owner, even if owner is absent at time of installation. When ordering hardwood flooring, it is recommended to add to the square footage needed an allowance for cutting waste.

WARRANTY

Structural lifetime warranty

Finish warranty

Boa-Franc guarantees the original purchaser that the Nanolinx™ HD and DuraMatt™ finishes applied on its Mirage prefinished hardwood floor will not wear through or separate from the wood for a period of:

- **Thirty-five [35] years** from the date of purchase, when used under normal **residential traffic conditions**;
- **Three [3] years** from the date of purchase, when used under **light commercial conditions**;
- **Five [5] years** from the date of purchase, on **Nanolinx™ Commercial** finish, when used under **commercial conditions**, excluding heavy commercial use.

Surface wear must be readily visible and cover at least ten percent [10%] of the total flooring surface area.

Disclaimer

- The nature of Sweet Memories, Alive, Imagine, Flair collections, American Walnut, Hickory and White Oak flooring explains the appearance of certain characteristics visible at time of purchase or developing over time, including, pronounced color variations, open and closed knots, mineral streaks, cracks, surface holes, and other character or milling marks are part and parcel of this effect.
- Some distinctive marks may become prominent over time due to changes in the environment.

CE Marking: For more information on CE Marking and to access our Declaration of Performance, go to www.miragefloors.com/cemarking.

For more information on the warranty, consult the Mirage Warranty Certificate. In the event of a discrepancy between the information in the Installation Guide and the Mirage Warranty Certificate, the latter shall prevail.

FLOOR CARE PREVENTION TIPS

For information on floor care prevention, consult Mirage's Residential Maintenance and Warranty Certificate on our website www.miragefloors.com.

Boa-Franc, G.P., Technical Service Department
 1255, 98th Street, Saint-Georges [Quebec] Canada G5Y 8J5
 Tel.: 418-227-1181 – 800-463-1303 – Fax: 418-227-1188
 Or by e-mail: technical@boa-franc.com





RECOMMENDED TOOLS, MATERIAL AND ACCESSORIES

- Vacuum cleaner or broom
- Scraper
- Leveling bar
- Level
- Leveling compound [optional]
- #20 grit sand paper [optional]
- Wood and/or concrete moisture meter
- Miter saw
- Handsaw
- Security glasses
- Claw hammer
- Nail punch
- Pry bar
- Square 16" x 24"
- Measuring tape
- Chalk line
- Reversing tongues [optional]
- *Mirage Touch* [touch up kit]
- *Mirage Clean* [maintenance kit]

Glued down installation

- Recommended adhesives:
 - Use adhesive that meets the performance criteria described in Mirage technical newsletter #23 at www.miragefloors.com in the Guide and Support section.
- Trowel recommended by adhesive manufacturer as tooth size is important for ensuring optimal strip adherence to subfloor.
- 2" [50 mm] concrete nails and 1" x 3" x 8' [25 mm x 75 mm x 245 cm] laths for first- row holding block.
- 3M blue adhesive tape or easily removable equivalent.
- 100 to 150 lbs [45 to 68 kg] pound roller.
- Remover towels for hand and tool cleaning.
- Adhesive cleaner.
- Recommended membrane if necessary. Refer to technical newsletter #26 in the Guide and Support section at miragefloors.com.

Stapled/nailed down installation

- Pneumatic staplers/nailers.
- Staples/nails recommended in the technical newsletter #30 in the Guide and Support section at miragefloors.com.
- Power drill and 1/16" [1.5 mm] bit.
- Finishing nails [selected on flooring thickness]: 1-1/2" [38 mm] up to 2" [63 mm].
- Flooring screws

Prefinished accessories such as reducers, stair nosing, etc. are available from your Mirage Authorized dealer.

Note: Boa-Franc cannot be held responsible for any floor damage resulting from use of inadequate tools or adhesive, differing from those recommended. All the installation material must be at the recommended room temperature prior to the installation $\pm 72^\circ\text{F}$ [$\pm 22^\circ\text{C}$].



Glued down

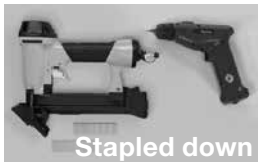

Stapled down



Nailed down

HANDLING AND ACCLIMATIZATION

Prefinished hardwood floor installation **requires a little more time and precaution than unfinished flooring**; handle with care to avoid board surface and finish damage.

PRE-INSTALLATION CHECK LIST

Basic requirements

- Hardwood floor installation should be the very last step of any construction or renovation project.
- Prior to installation, heating system must be in operation, and room temperature must have been maintained at $\pm 72^\circ\text{F}$ [$\pm 22^\circ\text{C}$] for at least one week.
- To avoid any moisture-related damages, subfloor must be dry and basement well ventilated.
- For below grade installation, ensure that foundations, concrete slab or any adjacent objects are thoroughly leak proof.
- **Relative humidity must be maintained around 45% during pre-installation and installation phases.**
- **Radiant heat performance:**
 - Installation over subfloors equipped with radiant heat systems must be glued down.
 - The radiant heat system must have been tested and in operation for a few weeks prior to installation.
 - The system should be turned off during installation and turned back on 24 hours after installation to allow the glue to dry normally.
 - The wood surface temperature must never exceed 80°F [27°C].
 - If the radiant heat pipes are visible or exposed in the subfloor, you must cover them with 3/8" [10 mm] plywood to spread heat more evenly.
 - Due to their specific physical properties, Brazilian Cherry [Jatoba] and Hickory must not be installed on subfloors over radiant heat systems.

Subfloor moisture level check

Wooden subfloor: Wooden subfloor moisture reading must not exceed 12% and differential between boards and subfloor must be less than 4%. Wood moisture meters are available from your Mirage Authorized dealer. If moisture reading is too high, postpone installation, find moisture source and correct it if needed, raise heat and increase ventilation until proper conditions are met.

Concrete subfloor: Prior to installation, concrete subfloor should preferably be 45 to 90 days old, **30 days being the absolute minimum**. Concrete moisture meter must be used to check subfloor moisture level; if the result exceed 3.5%, calcium chloride test must be performed. **The concrete subfloor moisture content must not exceed 3 lbs / 1,000 sq. ft. /24 hours.** If the reading exceeds 3 lbs, use a complete moisture-proofing system [sealer and adhesive] compatible with the selected adhesive. Please refer to the manufacturer's documentation for the selected products for information on their warranty, product limitations, and installation recommendations.

Note: Keep sealed boxes of wood in room where flooring is to be installed for at least 24 hours before installation.

Owner and installer are solely and jointly responsible for pre-installation subfloor moisture level check and must ensure that all conditions and/or specifications listed in this guide have been thoroughly met prior to installation of hardwood floor.

SUBFLOOR PREPARATION

- Stapled or nailed down installation requires minimum 5/8" [16 mm] plywood, or 23/32" [18 mm] OSB chipboard subfloor.
- **Sound:** Wooden subfloor must be securely screwed down to joists to prevent any movement or squeaks. Thoroughly inspect and replace existing floor or subfloor that shows evidence of water damage or structural weakness. Concrete subfloor must be just as structurally sound before installing hardwood floor and should be rated with a minimum compressive strength of 3000 psi.
- **Flat:** Subfloor surface must be flat and maximum tolerance is 3/16" [5 mm] per 10' [3 m]. If necessary, flatten down any irregularities, using #20 grit paper, and correct any uneven spots.
- **Dry:** Subfloor must be dry and within moisture reading specs.
- **Clean:** Vacuum and free subfloor from any debris or obstacles such as cleats, nail heads, dried glue or any other material.

PREPARATION

- Sketch installation to avoid surprises.
 - Decide starting point or wall.
 - Decide layout angle.
- Remove any baseboard, doorsill and old floor covering if necessary.
- Trim bottom of the doorstop with handsaw to insert boards underneath.
- To enhance the floor's look, use several boxes at once and mix boards to ensure variations in color, shade and length.
- Start by selecting the boards that will best go with the transition moldings.

GLUED DOWN INSTALLATION INSTRUCTIONS [Illustration #1]

Wear your security equipment and maintain a safe environment at all times.

Step I: Starting point

- Using a chalk line, make a starting **A** mark parallel to starting wall **B**. The distance from the parallel wall and the starting line is based on the board widths. See the table below.

Board widths	Distance between wall and starting line
2-9/16" (65 mm)	31" (788 mm)
3-5/16" (84 mm)	33-3/8" (848 mm)
5" (127 mm)	30-1/4" (768 mm)
6-1/2" (165 mm)	32-11/16" (832 mm)
7-3/4" (197 mm)	31-1/4" (794 mm)

Working area **C** between starting wall and starting line, will be last floor section laid. Above measurements account for ideal fit, so that it will not be necessary to rip-saw finishing board row, while allowing for required 1/4" [6 mm] expansion **D** gap.

- Holding block, **E** must be nailed down alongside starting line inside working area to secure starting row in place.

Step II: Adhesive application

- For optimal adhesive application, work **F** trowel in circular motion at 45° angle; adhesive left on floor by trowel teeth is just the right amount. [One gallon covers about 45 to 50 sq. ft. depending on manufacturer's specs. See container.]

Note: Only cover surfaces that can be reasonably laid in two hours, since adhesive may dry too quickly and not stick properly. Reaction time may vary from one adhesive to another and may also be affected by room temperature and relative humidity [see manufacturer's specs on container].

Step III: Board laying

- It is very important that installation be started straight and square.
- Carefully select boards. As needed, cut boards that appear different or move them to a less visible location.
- Laying from working area, leave 1/4" [6 mm] gap alongside left wall which is perpendicular to starting line, prop tongue side against holding block and press first board **G** down into adhesive.
- Install subsequent boards **H**, proceeding from left to right until ready to trim first-row end board.
- To minimize trim waste, select board long enough **I** for row end, so that remaining trimmed end may be used to start subsequent row. Leave 1/4" [6 mm] gap at end of each row. **J**

- First board of second row must be at least 6" [150 mm] shorter or longer than that of first row. Cross joints must be staggered by at least 6" [150 mm] from one row to the next. Avoid lining the joints up or having them follow too regular a pattern [illustration #4].
- Insert tongue end into board groove, lower board as close as possible to adjacent one, slide tongue into groove and press board down.
- Proceed the same way for subsequent rows.
- Once main part of floor has been laid, remove blocking laths from working area and complete installation in the same manner. Use pry bar to fit last row of boards into place and be sure to leave minimum required 1/4" [6 mm] expansion gap.

Notes:

- When used, acoustic underlayment must be glued down over subfloor prior to gluing down boards using the same recommended adhesive.
- Extremely precise board milling may require use of tapping block for better tongue and groove fit.
- Row to row installation requires that no glue seeps into grooves at any time for perfect tongue and groove fit.
- Avoid getting adhesive on hands to minimize clean up. **Wipe any adhesive from floor right away**, using solvent and towels. Use paint thinner or lighter fluid to remove stubborn adhesive spills.
- To maintain boards in place and avoid board movement causing gapping during installation, use 3M blue adhesive tape.
- For better board contact with adhesive, it is recommended to use adhesive manufacturer's recommended pound weight roller [usually 100 to 150 lbs / 45 to 68 kg required] over laid floor section **before adhesive dries**. Use roller's protective padding to avoid damage to floor surface.

Step IV: Accessories installation

- Set a few boards aside in case of future repairs.
- When installation is completed, vacuum floor thoroughly, spray light mist of Mirage Clean on terry cloth mop and clean floor.

Step V: Post-installation

- Wait 24 hours before moving furniture back into place or allowing heavy traffic.
- Set a few boards aside in case of future repairs.
- When installation is completed, vacuum floor thoroughly, spray light mist of Mirage Clean on terry cloth mop and clean floor.

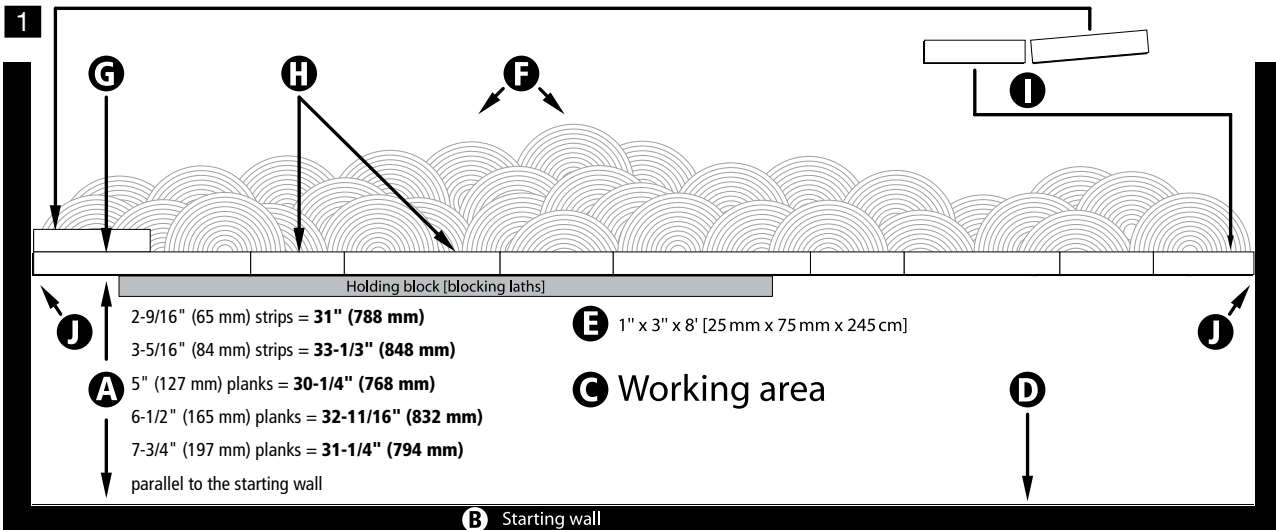

NAILED/STAPLED DOWN INSTALLATION INSTRUCTIONS

(Illustration #2 and #3)

Wear your security equipment and maintain a safe environment at all times.

Step I: Starting point

Using a chalk line, make a starting mark **A** parallel to starting wall. The distance from the parallel **B** wall and the starting line is based on the board widths. See the table below.

Board widths	Distance between wall and starting line
2-9/16" (65 mm)	2-13/16 po (71 mm)
3-5/16" (84 mm)	3-9/16 po (90 mm)
5" (127 mm)	5-1/4 po (133 mm)
6-1/2" (165 mm)	6-3/4 po (191 mm)
7-3/4" (197 mm)	8 po (203 mm)

This mark is parallel to starting wall and perpendicular to adjacent one. These measures account for minimum 1/4" (6 mm) expansion gap alongside wall.

Step II: Board laying

- It is very important that installation be started straight and square.
- Carefully select boards. As needed, cut boards that appear different or move them to a less visible location.
- Align first board tongue side with starting line, **A** grooved side facing starting wall; leave 1/4" (6 mm) gap from right side wall **E** which is perpendicular to starting line. Drill and nail board vertically **C** as close to wall as possible to hide nail heads when baseboards and quarter rounds **D** are in place. Install subsequent boards from right to left until ready to trim row end board.
- To minimize trim waste, select board long enough for row end, so that remaining trimmed end may be used to start subsequent row. Leave 1/4" (6 mm) gap at end of each row **E**.
- First board of second row must be at least 6" (150 mm) shorter or longer than that of first row. Cross joints must be staggered by at least 6" (150 mm) from one row to the next. Avoid lining the joints up or having them follow too regular a pattern (illustration #4).
- Since wall proximity prohibits use of stapler/nailer, use finishing nails approximately every 4" (100 mm) alongside tongue **F** for first few rows, and punch nail heads down.
- Subsequent rows must be installed the same way, using the stapler/nailer; nail boards every 4 to 5" (100 to 125 mm), but at more than 2" (50 mm) from each board end (see pneumatic stapler/nailer tips and technical newsletter #30 in the Guide and support section at miragefloors.com).
- Because of wall proximity, installation of last 4 or 5 rows is identical to installation of first few rows. You might have to rip-saw last row of boards to leave required 1/4" (6 mm) gap **E** alongside finishing wall.

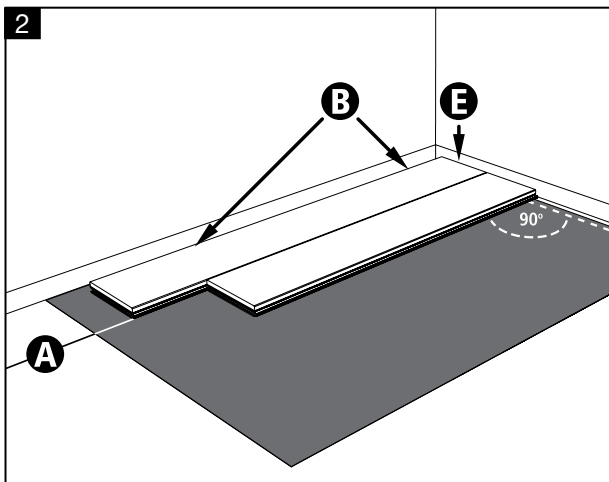

Note:

- Extremely precise board milling may require use of tapping block for better tongue and groove fit.

Step III: Accessories installation

- If applicable, install transition moldings, stair nosings and reducers.
- If applicable, reinstall baseboards and quarter rounds, making sure to nail them only to walls and not to floor (to allow free floor movement).

Step IV: Post-installation

- Set a few boards aside in case of future repairs.
- When installation is completed, vacuum floor thoroughly, spray light mist of *Mirage Clean* on terry cloth mop and clean floor.

PNEUMATIC NAILER/STAPLER TIPS

Warning

To avoid damaging boards during installation:

- Ensure that stapler/nailer base plate remains clean and free from nicks at all times.
- When stapler/nailer is not being used, place on piece of plywood or cardboard, but never directly onto floor.
- Ensure that stapler/nailer base sits flat on floor and plumb against tongue before stapling board down.
- Check base plate condition and proper operation of stapler/nailer regularly.**
- Set and check air pressure regularly on subfloor types requiring specific air pressure settings.

